

# SURFACE MOUNTING BOX



## Features

The Surface Mounting Box allows for quick and easy integration of the connected module while protecting it from small splashes of water thanks to its IP44 standard.



### IP 44 RATING

The Surface Mounting Box is IP44 certified, which makes it safe for use in damp rooms

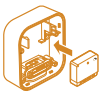

### COMPATIBLE WITH NODON MODULES

The Surface Mounting Box is compatible with all our SIN type modules (supplied with a cable compatible with most uses).



### MODULE ASSEMBLY/QUICK CONNECTION

The module is quickly fixed in the Surface Mounting Box by means of the inner notches and the outer cover and the outer cover

## Technical specifications

**Operational temperature:** 0°C to 40°C

**Protection rating:** IP 44

**Dimension:** 80 mm (l) x 93 mm (L) x 29.5 mm (h)

**Cable supplied:** 4x1.5 length 1.40 m

**Weight:** 100g excluding module and cable

**Warranty:** 2 years

## Efficiency



Easy access to the module once the box is installed

## Renovation

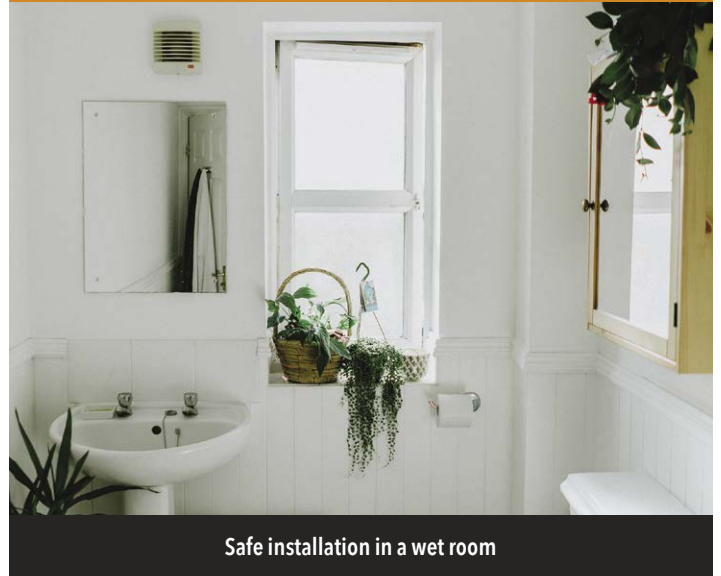



Safe installation in a wet room

## Content

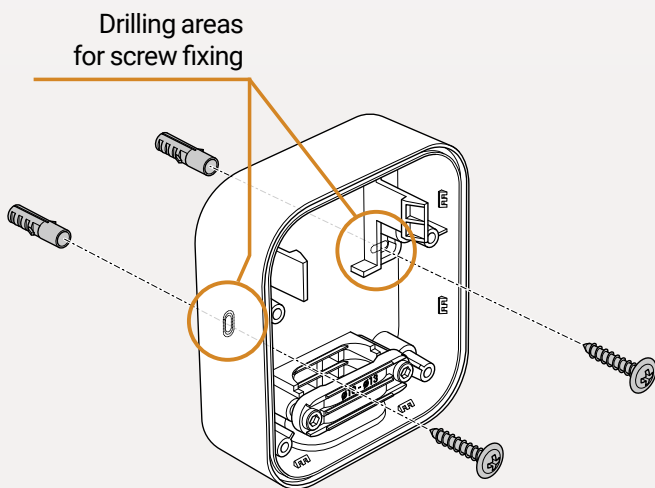

## Installation



 Drill through the inside of the housing

## Dimensions

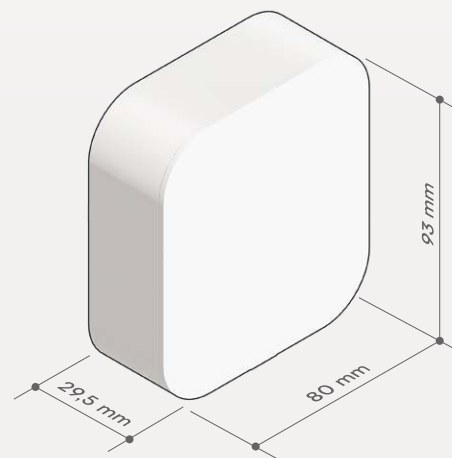

## Reference

BPS-1-1-00  
EAN: 3700313925683